

General

The hipecs-CIO51 is a compact CANopen module providing 2 Full-Bridge-Drivers to drive DC motors, valves or similar loads. The device uses PWM, the base frequency can be adjusted in from 500 Hz up to 12 kHz.

To relieve the master automatic ramp generation is possible.

The hipecs-CIO51 supports a current limiting function measuring of internal system temperature with automatic over-heating protection.

CANopen is available according to DS301 and DS401. All usual baud rates up to 1 Mbit/s supported.



Features

- 2 Full-Bridge-Driver, +24 V DC/+1.0 A, PWM controlled
- Current measuring and limiting
- Thermal shutdown protection
- Plastic housing for mounting onto DIN carrier rails
- Operating temperature 0...+55 °C (opt. -40...+70 °C)

CANopen Features

- CAN baud rates up to 1 Mbit/s
- CAN bus ISO11898 with Transceiver TJA1050
- 4 Transmit- and 4 Receive-PDO
- Dynamic PDO Mapping
- Variable PDO Identifier
- CANopen PDO transfer modes: synchronous, asynchronous, event triggered, cyclic, acyclic and RTR
- Event Timer and Inhibit Timer for all Transmit-PDO
- Node-Guarding, Lifeguarding und Heartbeat
- Emergency messages
- Minimum Boot-Up

Ordering information

Part	Order number
hipecs-CIO51-i	EZ00000.2151.01
2 Full-Bridge-Driver, CAN isolated, 0...+55 °C	
hipecs-CIO51-ie	EZ00000.3051.00
2 Full-Bridge-Driver, CAN isolated, -40...+70 °C	

Technical data

Separated power supply for system/bus and outputs.

Power supply System	Min.	Norm.	Max.
Supply voltage System/Bus	+11 V DC	+24 V DC	+32 V DC
Current consumption System/Bus	+20 mA (at V _{CC} = +32 VDC)	+30 mA	+60 mA (at V _{CC} = +11 V DC)
Supply voltage I/O		+24 V DC	
CAN bus Norm	ISO11898		
CiA Draft Standards	DS301 Version 4.0 and DS401 Version 2.0		
Conformance declaration	CE		
MBTF	5,634,880 hrs		

Digital Outputs	
Number of outputs	2
Switching character	Full-Bridge
Protection	Thermal shutdown
Max. temperature internal	+55...+85 °C selectable
PWM frequency	500...12,000 Hz via Prescaler
Delay (CAN reaction time)	typ. 1 ms
max. output current continuous	+1.0 A
Peak output current	+2.0 A max. 1 s

Connectors and dimensions	
Connectors	Screw clamps
Cable cross-section [mm ²]	0.08...1.5 mm ² (massive/flexible)
Cable cross-section [AWG]	26...14 AWG (massive/flexible)
Stripping length	8 mm
Dimensions housing	approx. 17.8 x 90 x 62 mm (see picture "dimensions"!)
Operating temperature	0...+55 °C (optional -40...+70 °C)
Weight module	approx. 60 g

Connectors assignment

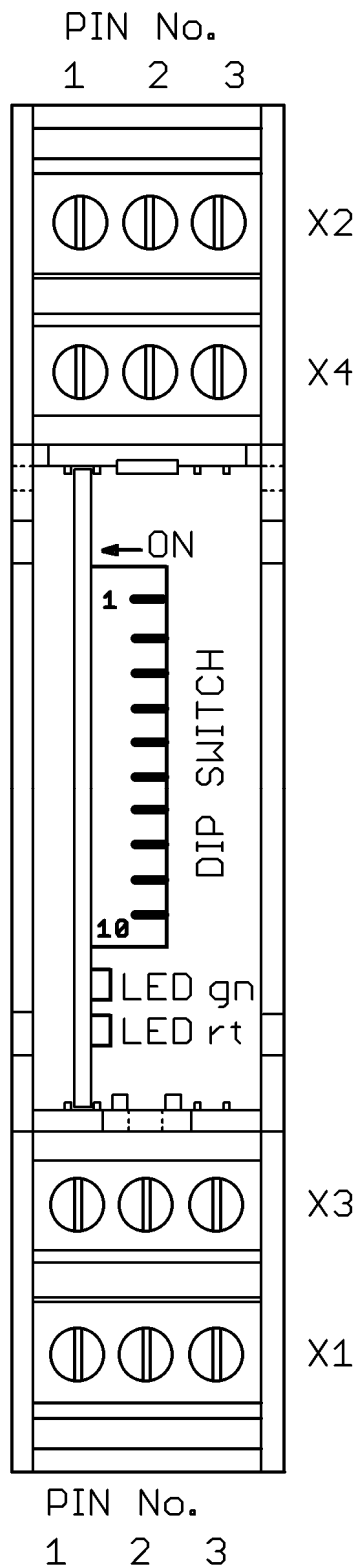

Connector X1 (power)

Pin-No.	Name	Description
1	U	+ 24 V DC
2	GND	Ground
3	G1	Ground outputs

Connector X2 (CAN)

Pin-No.	Name	Description
1	L0	CAN Low
2	H0	CAN High
3	G0	Ground

Connector X3 (output 2)

Pin-No.	Name	Description
1	2L	Output 2 Low
2	P1	Power outputs
3	2H	Output 2 High

Note: Connect load always between X3.1 and X3.3.

Connector X4 (output 1)

Pin-No.	Name	Description
1	1L	Output 1 Low
2	-	-
3	1H	Output 1 High

Note: Connect load always between X4.1 and X4.3.

Wiring diagram

Single supply

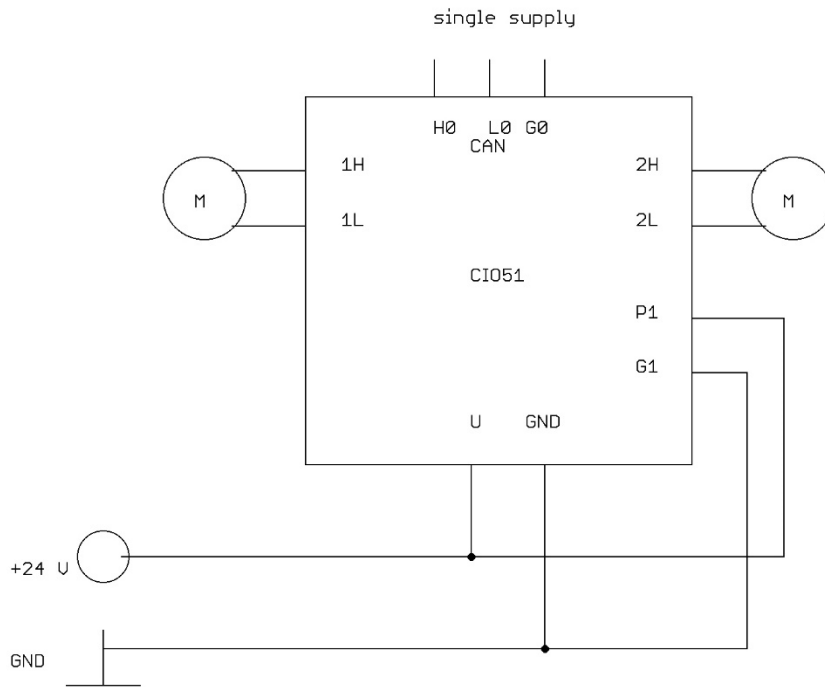

Dual supply

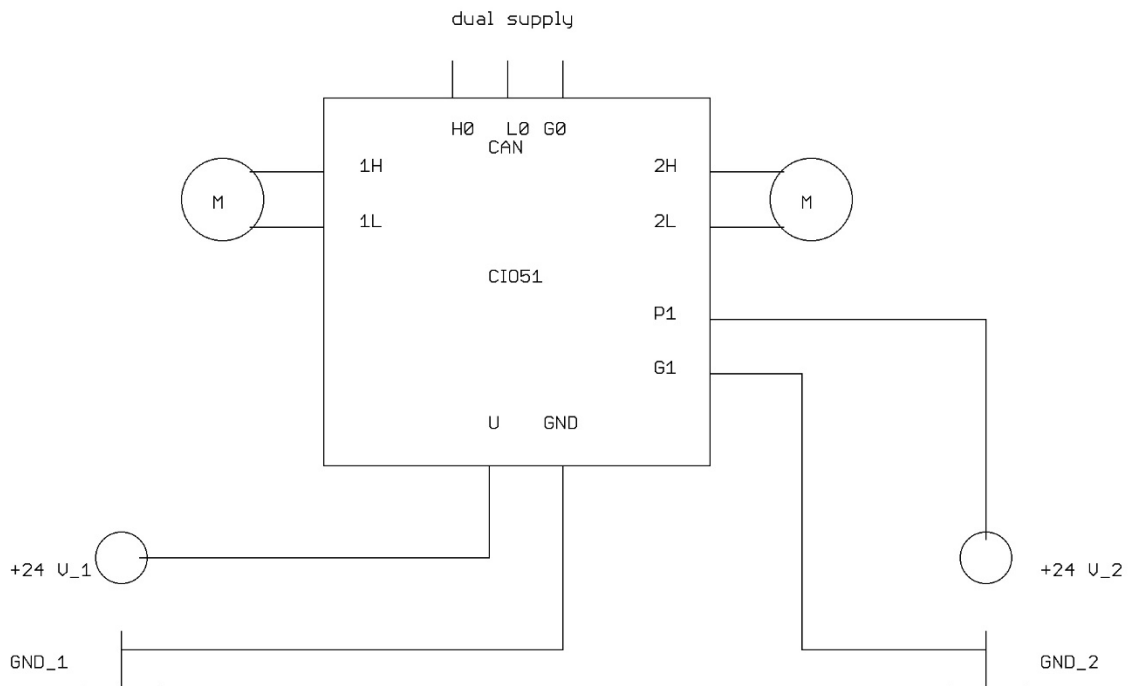

Configuration Dip-Switch

Configuration of node-ID, baud rate and termination via DIP-Switch.
The switches are inside the housing (open lid).

Switch Number										Description
1	2	3	4	5	6	7	8	9	10	
RT										RT Termination CAN-Bus
	BD2	BD1	BD0							BDx Baud rate CAN-Bus
				ID5	ID4	ID3	ID2	ID1	ID0	IDx Select Node-ID
ON										CAN-Termination on (120 Ohm)
OFF										CAN-Termination off
	OFF	OFF	OFF							1 MBit/s
	OFF	OFF	ON							800 kBit/s
	OFF	ON	OFF							500 kBit/s
	OFF	ON	ON							250 kBit/s
	ON	OFF	OFF							125 kBit/s
	ON	OFF	ON							50 kBit/s
	ON	ON	OFF							20 kBit/s
	ON	ON	ON							Reserved
				OFF	OFF	OFF	OFF	OFF	OFF	Reserved
				OFF	OFF	OFF	OFF	OFF	ON	Node-ID = 1
				OFF	OFF	OFF	OFF	ON	OFF	Node-ID = 2
				OFF	OFF	OFF	OFF	ON	ON	Node-ID = 3
			
				ON	ON	ON	ON	OFF	OFF	Node-ID = 60
				ON	ON	ON	ON	OFF	ON	Node-ID = 61
				ON	ON	ON	ON	ON	OFF	Node-ID = 62
				ON	ON	ON	ON	ON	ON	Node-ID = 63

CAN Signal-LED

The LED are located behind the lid. States are coded according to DRP303-3.

LED	Farbe	Funktion
RUN-LED	green	Off no supply or faulty Flickering CAN not started flashing Stopped blinking Preoperational on Operational
ERR-LED	red	off no error 1x flashing CAN module in Error Warning State 2x flashing Node-Guarding error on Bus-Off

Dimensions

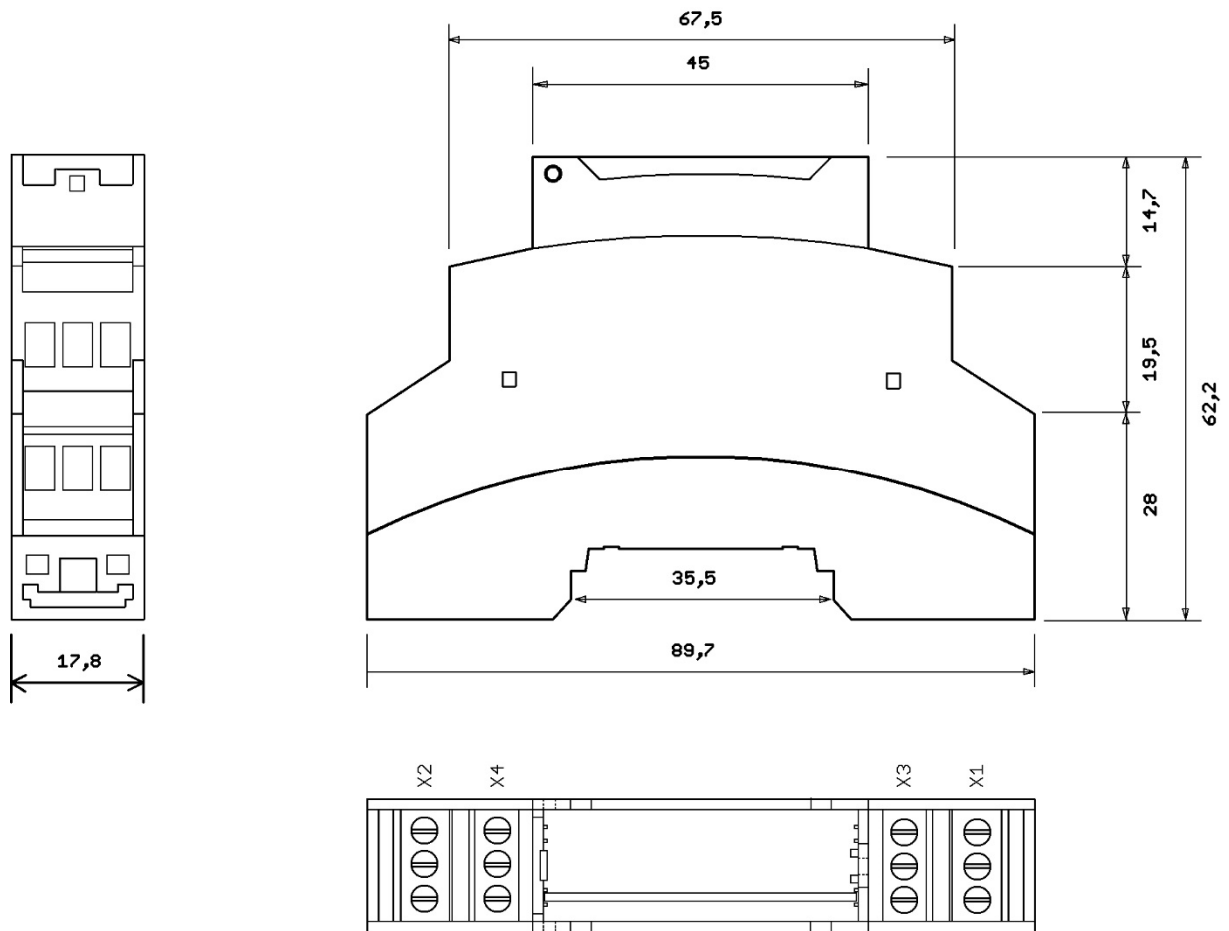

All measurements in millimeter (mm)

CANopen Object Dictionary

DS301: global objects

Index	Sub-Index	Name	Access
0005	-	Dummy 8	r/o
0006	-	Dummy 16	r/o
0007	-	Dummy 32	r/o
1000	-	Device Type	r/o
1001	-	Error Register	r/o
1002	-	Manufacturer Status Register	r/o
1005	-	COB-ID SYNC	r/o
1008	-	Device Name	r/o
1009	-	Hardware Version	r/o
100A	-	Software Version	r/o
100C	-	Guard Time	r/w
100D	-	Life Time Factor	r/w
100E	-	COB-ID Guard	-
1014	-	COB ID Emergency	r/w
1015	-	Inhibit Time Emergency	r/w
1016	0	Consumer Heartbeat Time	r/o
	1	Consumer Heartbeat Time 1	r/w
	2	Consumer Heartbeat Time 2	r/w
	3	Consumer Heartbeat Time 3	r/w
	4	Consumer Heartbeat Time 4	r/w
1017	-	Producer Heartbeat Time	r/w
1018	0	Identity Object	r/o
	1	Vendor ID	r/o
	2	Product Code	r/o
	3	Revision Number	r/o
	4	Serial Number	r/o
1029		Error Behavior Object	r/o
	1	Communication error	r/w
	2	Application error	r/w

All index values are hexadecimal. Values in tables are hexadecimal (0x...) or decimal.

r/o read only
w/o write only
r/w read and write

All visible string data types are 20 characters at max.

DS301: PDO Parameter objects

Description of PDO Parameter. With these indexes, dynamic PDO-Mapping, free selection of IDs, transmission type, inhibit and event time is possible. These settings are selectable in "operational" as well as "preoperational" mode.

Index	Sub-Index	Name	Access
1400	0	Receive-PDO1 Communication Parameter	r/o
	1	COB-ID	r/w
	2	Transmission Type	r/w
1401...1403		Receive-PDO2 to RPDO4 Communication Parameter same as 1400	r/w
1600	0	Receive-PDO1 Parameter mapping	r/w
	1 to n	Mapped objects (max. 8 objects mappable)	r/w
1601...1603		Receive-PDO2 to RPDO4 Parameter mapping same as 1600	r/w
1800	0	Transmit-PDO1 Communication Parameter	r/o
	1	COB-ID	r/w
	2	Transmission Type	r/w
	3	Inhibit Time	r/w
	4	Reserved	r/w
	5	Event Time	r/w
1801...1803		Transmit-PDO2 to TPDO4 Communication Parameter same as 1800	r/w
1A00	0	Transmit-PDO1 Parameter mapping	r/w
	1 to n	Mapped objects (max. 8 objects mappable)	r/w
1A01...1A03		Transmit-PDO2 to TPDO4 Parameter mapping same as 1A00	r/w

Specific objects

Index	Sub-Index	Name	Access
2000	-	Device Manufacturer	r/o
2009	0	Serial Number 64 Bit	r/o
	1	Serial Number 64 Bit LSDW	r/o
	2	Serial Number 64 Bit MSDW	r/o
2101	-	System Configuration	r/o
2102	-	Remapping Enabled Info	r/o
2103	-	Enable Guarding Warning	r/w
2105	-	Internal API State	r/o
2110	0	Conformance Test Object	r/o
	1	Range Check Object	r/w
2180	-	CAN Restart Time	r/w

DS401: digital inputs

Index	Sub-Index	Name	Access
6000	0 to n	Read digital input 8 bit	r/o
6002	0 to n	Polarity input 8 bit	r/w
6005	-	Global Interrupt Enable	r/w
6006	0 to n	Interrupt Mask Any Change	r/w
6007	0 to n	Interrupt Mask Rising Edge	r/w
6008	0 to n	Interrupt Mask Falling Edge	r/w
6100	0 to n	Read Digital Input 16 Bit	r/o
6120	0 to n	Read Digital Input 32 Bit	r/o

DS401: digital outputs

Index	Sub-Index	Name	Access
5200	-	Reset Output Object on Error	r/w
6200	0 to n	Write Output 8 Bit	r/w
6206	0 to n	Error Mode Output	r/w
6207	0 to n	Error State Output	r/w
6300	0 to n	Write Digital Output 16 Bit	w/o
6320	0 to n	Write Digital Output 32 Bit	w/o

DS401: analog inputs

Index	Sub-Index	Name	Access
5300	-	Analog Input Mode	r/w
5301	-	Analog Input Filter Level	r/w
5310	-	Input Calibration	r/w
6401	0 to n	Analog Input 16 Bit	r/w
6421	0 to n	Analog Input Trigger Selection	r/w
6423	-	Analog Interrupt Enable	r/w
6424	0 to n	Analog Input Interrupt Upper Limit	r/w
6425	0 to n	Analog Input Interrupt Lower Limit	r/w
6426	0 to n	Analog Input Interrupt Delta	r/w
6427	0 to n	Analog Input Interrupt Negative Delta	r/w
6428	0 to n	Analog Input Interrupt Positive Delta	r/w

DS401: analog outputs

Index	Sub-Index	Name	Access
5400	-	Analog Output Reset on Error	r/w
6411	0 to n	Analog Output 16 Bit	r/w
6443	0 to n	Analog Output Error Mode	r/w
6444	0 to n	Analog Output Error Value	r/w

Product related specific objects sorted by function

Index	Sub-Index	Name	Access
5104	0 to n	Output Driver Max. Current mA	r/w
5109	0 to n	Output Current Max. Change Prescaler	r/w

**Current
change**

Index	Sub-Index	Name	Access
5107	-	Output PWM Prescaler	r/w
5108	0 to n	Output PWM Max. Change per ms	r/w

PWM

Index	Sub-Index	Name	Access
51F0	-	Overheat Limit Temperature	r/w

Temperature

Object dictionary (description)

Following comes a short description of every dictionary entry.

DS301: Global objects

Index 0005

Dummy for spaces in PDO mapping (8-bit length).
Can be used, more than once.

Index	0005
Name	Dummy 8
Description	
Data Type	Unsigned 8
Access	r/o
PDO Mapping	Yes
Value Range	-
Default Value	0

Index 0006

Dummy for spaces in PDO mapping (16-bit length).
Can be used, more than once.

Index	0006
Name	Dummy 16
Description	
Data Type	Unsigned 16
Access	r/o
PDO Mapping	Yes
Value Range	-
Default Value	0

Index 0007

Dummy for spaces in PDO mapping (32-bit length).
Can be used, more than once.

Index	0007
Name	Dummy 32
Description	
Data Type	Unsigned 32
Access	r/o
PDO Mapping	Yes
Value Range	-
Default Value	0

Index 1000: Device Type

This index contains a description of the device type. Within are encoded the CiA profile code and additional specifications of the device.

Index	1000
Name	Device Type
Description	-
Data Type	Unsigned 32
Access	r/o
PDO Mapping	No
Value Range	-
Default Value	0x0083 0191

Index 1001: Error Register

This index contains the internal error code in case of emergency.

Index	1001
Name	Error Register
Description	-
Data Type	Unsigned 8
Access	r/o
PDO Mapping	Yes
Value Range	-
Default Value	-

The error register is built as shown. If more than one error occur, the values are combined via logical OR.

Bit	Description
0	Common error. This bit is set with every error.
1	0
2	0
3	0
4	CAN bus or communication error
5	0
6	0
7	Device error

Index 1002: Status Register

This index contains additional status information of the device.

Index	1002
Name	Status Register
Description	-
Data Type	Unsigned 32
Access	r/o
PDO Mapping	Yes
Value Range	-
Default Value	-

Index 1005: COB-ID SYNC

This index sets the COB-ID for SYNC messages.

This device is a receiving device. SYNC production is not supported.

Index	1005
Name	COB-ID Sync
Description	-
Data Type	Unsigned 32
Access	r/w
PDO Mapping	No
Value Range	1..0x7FF
Default Value	0x80

Index 1008: Device Name

This index contains the device name as a visible string.

¹⁾ xxx: Number of the product

Index	1008
Name	Device Name
Description	-
Data Type	Visible String
Access	r/o
PDO Mapping	No
Value Range	The maximum string length is 20 characters
Default Value	"hipecs-C10xxx ¹⁾ "

Index 1009: Hardware Version

This index contains the revision code of the hardware as visible string.

Index	1009
Name	Hardware Version
Description	-
Data Type	Visible String
Access	r/o
PDO Mapping	No
Value Range	The maximum string length is 20 characters
Default Value	-

Index 100A: Software Version

This index contains the firmware version as visible string.

Index	100A
Name	Software Version
Description	-
Data Type	Visible String
Access	r/o
PDO Mapping	No
Value Range	The maximum string length is 20 characters
Default Value	-

Index 100C: Guard Time

Together with index 100D, this index represents the lifeguarding protocol. Values are in milliseconds.

Guard Time multiplied by Life Time Factor results in Life Time.

Set up 0 (zero), if not used.

Index	100C
Name	Guard Time
Description	-
Data Type	Unsigned 16
Access	r/w
PDO Mapping	No
Value Range	
Default Value	0

Index 100D: Life Time Factor

Together with index 100C, this index represents the lifeguarding protocol. Values are factors.

Guard Time multiplied by Life Time Factor results in Life Time.

Set up with 0 (zero), if not used.

Index	100D
Name	Life Time Factor
Description	-
Data Type	Unsigned 8
Access	r/w
PDO Mapping	No
Value Range	
Default Value	0

Index 100E: COB-ID Guard

This index contains the ID for guarding protocol.

Index	100E
Name	COB-ID Guard
Description	-
Data Type	Unsigned 32
Access	-
PDO Mapping	No
Value Range	-
Default Value	0x700 + Node-ID

Index 1014: COB-ID Emergency

This index sets the ID for emergency messages.

Index	1014
Name	COB-ID Emergency
Description	-
Data Type	Unsigned 32
Access	r/w
PDO Mapping	No
Value Range	-
Default Value	0x80 + Node-ID

Index 1015: Inhibit Time Emergency

This index sets up a delay for transmitting any emergency. This device supports a delay with an interval of one millisecond.

Index	1015
Name	Inhibit Time Emergency
Description	-
Data Type	Unsigned 16
Access	r/w
PDO Mapping	No
Value Range	-
Default Value	0 (disabled)

Index 1016: Consumer Heartbeat Time

Index 1016 is used to monitor the Heartbeat Consuming of up to four nodes.

Index	1016
Name	Consumer Heartbeat Time
Description	-
Data Type	Structure

Attention:

Heartbeat monitoring starts with the reception of the first heartbeat.

The Producer Time should be greater than the Consumer Time.

Ahead of the first heartbeat, the Producers status is unknown.

Index	1016.00
Name	Number of indexes supported
Description	-
Data Type	Unsigned 8
Access	r/o
PDO Mapping	No
Value Range	-
Default Value	4

Structure of the Consumer Heartbeat Time

MSB		LSB	
Byte3	Byte2	Byte1	Byte0
Reserved	Node-ID	Heartbeat time	

Index	1016.01...1016.04
Name	Consumer Heartbeat Time 1...4
Description	-
Data Type	Unsigned 32
Access	r/w
PDO Mapping	No
Value Range	-
Default Value	0

Index 1017: Producer Heartbeat Time

This index sets up the heartbeat cycle in an interval of one millisecond.

If it is not used, set up 0 (zero).

Attention:

Use either Heartbeat or Node-Guarding. Both at once is not allowed.

Index	1017
Name	Producer Heartbeat Time
Description	-
Data Type	Unsigned 16
Access	r/w
PDO Mapping	No
Value Range	-
Default Value	0

Index 1018: Identity Object

This index contains common information about the device and the manufacturer, frenzel + berg electronic GmbH & Co.KG. It cannot be modified.

Index	1018
Name	Identity Object
Description	-
Data Type	Structure

Index	1018.00
Name	Number of indexes supported
Description	-
Data Type	Unsigned char
Access	r/o
PDO Mapping	No
Value Range	-
Default Value	4

Registration code of frenzel + berg electronic GmbH & Co.KG at the CiA

Index	1018.01
Name	Vendor ID
Description	
Data Type	Unsigned 32
Access	r/o
PDO Mapping	No
Value Range	-
Default Value	0x58

Internal product code of the product at frenzel + berg electronic GmbH & Co.KG

Index	1018.02
Name	Product Code
Description	
Data Type	Unsigned 32
Access	r/o
PDO Mapping	No
Value Range	-
Default Value	0x0300 5100

Index	1018.03
Name	Revision Code
Description	
Data Type	Unsigned 32
Access	r/o
PDO Mapping	No
Value Range	-
Default Value	Revision of the device

Index	1018.04
Name	Serial Number
Description	
Data Type	Unsigned 32
Access	r/o
PDO Mapping	No
Value Range	-
Default Value	0

Index 1029: Error Behavior

This index sets up whether the device switches its operating state in case of emergency, or not. Possible changes are Pre-Operational or Stopped. No change at all and keeping the current state is possible, too.

Index	1029
Name	Error Behavior Object
Description	-
Data Type	Structure

As communication error counts, e.g., Bus-Off, Heartbeat, Guarding or internal errors of the device.

Index	1029.00
Name	Number of indexes supported
Description	-
Data Type	Unsigned char
Access	r/o
PDO Mapping	No
Value Range	-
Default Value	2

The values of the states are as follows:

- 0 Pre-Operational (only if Operational)
- 1 no change
- 2 Stopped
- 3...255 reserved

Index	1029.01
Name	Communication Error
Description	NMT state change in case of communication error
Data Type	Unsigned 8
Access	r/w
PDO Mapping	No
Value Range	-
Default Value	0

Index	1029.02
Name	Application Error
Description	NMT state change in case of internal error due to hardware malfunction
Data Type	Unsigned 8
Access	r/w
PDO Mapping	No
Value Range	-
Default Value	0

DS301: PDO Parameter Objects

Communication Parameter Objects

The transmission type for Transmit- and Receive-PDO are set up with sub-index 2.

Type	PDO transmission				
	cyclic	acyclic	synchronous	asynchronous	RTR
0		X	X		
1-240	X		X		
241-251	Reserved				
252			X		X
253				X	X
254				X	
255				X	

The synchronous transmission types 0...240 and 252 are dependent on the SYNC signal. Asynchronous transmission is independent from the SYNC.

Type 0 is triggered by the SYNC, however, a transmission is only made, if the PDO data changes.

A value between 1 and 240 says the transmission is synchronous and cyclic. The transmission type represents the needed number of SYNCs for triggering the PDO.

Type 252 triggers a transmission with the next available SYNC, but only if a RTR releases the PDO.

Type 253 transmits the PDO immediately, however, only on RTR.

With type 254 and 255, the manufacturer or the device profile set the conditions.

An inhibit time can be set in sub-index 3. The PDO are triggered by their conditions, but only transmitted if the inhibit time is up. This time is set as a multiple of 100 µs, a value of 0 (zero) renders the function useless.

In mode 254/255, an additional Event Time is set. This timer running out is considered an event. The time is set as a multiple of 1 ms. This event triggers a PDO transmission in addition to other possible events.

Index 1400 is an example for Receive-PDO and index 1800 is an example for Transmit-PDO.

Index	PDO
1400...14xx	Receive-PDO1...Receive-PDOxx
1800...18xx	Transmit-PDO1...Transmit-PDOxx

Index	14xx/18xx
Name	Receive-/Transmit-PDOx Communication Parameters
Description	-
Data Type	Structure

Index	14xx.00/18xx.00
Name	Number of indexes supported
Description	-
Data Type	Unsigned 8
Access	r/o
PDO Mapping	No
Value Range	-
Default Value	2/5

1400.01	ID + 200	1800.01	ID + 180
1401.01	ID + 300	1801.01	ID + 280
1402.01	ID + 80000400	1802.01	ID + 80000380
1403.01	ID + 80000500	1803.01	ID + 80000480

The table shows the default PDO-ID values.
An Identifier von 8xxxxxxx means the PDO is rendered inactive. The CAN master has to assign a valid PDO-ID.

See table on top of the chapter.

Multiple of 1 μ s.

Multiple of 1 ms.

Index	14xx.01/18xx.01
Name	COB-ID
Description	Identifier for CAN-Object for PDO
Data Type	Unsigned 32
Access	r/w
PDO Mapping	No
Value Range	-
Default Value	

Index	14xx.02/18xx.02
Name	Transmission Type
Description	-
Data Type	Unsigned 8
Access	r/w
PDO Mapping	No
Value Range	-
Default Value	0xFF

Index	18xx.03
Name	Inhibit Time
Description	-
Data Type	Unsigned 16
Access	r/w
PDO Mapping	No
Value Range	-
Default Value	0

Index	18xx.04
Name	Reserved
Description	-
Data Type	-
Access	-
PDO Mapping	No
Value Range	-
Default Value	-

Index	18xx.05
Name	Event Time
Description	-
Data Type	Unsigned 16
Access	r/w
PDO Mapping	No
Value Range	-
Default Value	0

PDO mapping objects

The following table shows the PDO mapping entries. This is the same for all PDO. The mapping table is a linking index for entries of the object dictionary (e.g. data of digital outputs) and position in the PDO.

Sub-Index 0 gives the number of valid entries. The hipecs-CIO50 supports up to eight entries each PDO. In order to change the mapping, sub-index 0 has to be set to 0 (zero) first (inactive). Now the entries can be altered. If a new entry is mapped, the hipecs-CIO50 checks whether the entry is valid or not. Invalid entries result in an abort.

All eight sub-indexes are pointer to the entries. A value of 0 (zero) means no entry. The pointer's structure is:

MSB		LSB	
Byte3	Byte2	Byte1	Byte0
mapped index		sub-index	Length

Index and sub-index combined are the pointer; Length is the data length of the pointer's target in bit.

Index	160x/1A0x
Name	Receive-/Transmit-PDO Mapping Parameters
Description	-
Data Type	Array

Index	160x/1A0x.00
Name	Number of indexes supported
Description	Number of mapped objects
Data Type	Unsigned 8
Access	r/w
PDO Mapping	No
Value Range	-
Default Value	See table below

Index	160x/1A0x.01...160x/1A0x.08
Name	Mapped object
Description	
Data Type	Unsigned 32
Access	r/w
PDO Mapping	No
Value Range	-
Default Value	See table below

Receive-PDO

The hipecs-CIOxxx¹⁾ uses this default configuration for Receive-PDO.

Index	Entry	
Receive-PDO1		
1600.00	2	
1600.01	62000108	Control bridge driver 1
1600.02	62000208	Control bridge driver 2
Receive-PDO2		
1601.00	2	
1601.01	64110110	PWM Duty-Cycle driver 1
1601.02	64110210	PWM Duty-Cycle driver 2
Receive-PDO3		
1602.00	0	
Receive-PDO4		
1603.00	0	

Transmit-PDO

The hipecs-CIOxxx¹⁾ uses this default configuration for Transmit-PDO.

Index	Entry	
Transmit-PDO1		
1A00.00	2	
1A00.01	60000108	Status bridge driver 1
1A00.02	60000208	Status bridge driver 2
Transmit-PDO2		
1A01.00	3	
1A01.01	64010110	Current driver 1
1A01.02	64010210	Current driver 2
1A01.03	64010310	Internal temperature
Transmit-PDO3		
1A02.00	0	
Transmit-PDO4		
1A03.00	0	

¹⁾ xxx: Number of the product

Specific Objects

Index 2000: Device Manufacturer

Index	2000
Name	Device Manufacturer
Description	-
Data Type	Visible String
Access	r/o
PDO Mapping	No
Value Range	The maximum string length is 20 characters
Default Value	„FRENZEL + BERG“

Index 2009: Serial Number 64 Bit

This index contains the serial number of this device.

Index	2009
Name	Serial Number 64 Bit
Description	-
Data Type	Array

Index	2009.00
Name	Number of indexes supported
Description	-
Data Type	Unsigned 8
Access	r/o
PDO Mapping	No
Value Range	-
Default Value	2

Index	2009.01
Name	Serial Number Low Double Word
Description	Bits 0...31 of the serial number
Data Type	Unsigned 32
Access	r/o
PDO Mapping	No
Value Range	-
Default Value	-

Index	2009.02
Name	Serial Number High Double Word
Description	Bits 32...63 of the serial number
Data Type	Unsigned 32
Access	r/o
PDO Mapping	No
Value Range	-
Default Value	-

Index 2101: System Configuration

This index shows the current operating mode of the device.

Index	2101
Name	System Configuration
Description	-
Data Type	Unsigned 32
Access	r/o
PDO Mapping	No
Value Range	-
Default Value	0

Index 2102: Remapping Enabled Info

This index shows, whether remapping the PDO is allowed or prohibited.

0 = remapping prohibited

1 = remapping allowed

Index	2102
Name	Remapping Enabled Info
Description	-
Data Type	Unsigned 8
Access	r/o
PDO Mapping	No
Value Range	-
Default Value	1

Index 2103: Enabled Guarding Warning

This index enables an additional warning when Node-Guarding is used.

The CAN master is given an early report for an imminent Node-Guarding failure.

The warning is triggered when the Guard Time is up (Index 100C).

The NMT state remains unaffected.

Index	2103
Name	Enable Guarding Warning
Description	-
Data Type	Unsigned 8
Access	r/w
PDO Mapping	No
Value Range	-
Default Value	0

Index 2105: Internal Error Code

These are internal error messages of the CANopen controller.

Index	2105
Name	Internal Error Code
Description	-
Data Type	Unsigned 32
Access	r/o
PDO Mapping	Yes
Value Range	-
Default Value	0 (no error condition)

Index 2110: Test Object

This index is for internal test purposes only. It possesses no function and is not to use.

Index	2110
Name	Test Object 01
Description	-
Data Type	Structure

Index	2110.00
Name	Number of indexes supported
Description	-
Data Type	Unsigned char
Access	r/o
PDO Mapping	No
Value Range	-
Default Value	1

Index	2110.01
Name	Range Check Object
Description	-
Data Type	Unsigned 16
Access	r/w
PDO Mapping	No
Value Range	100...1000
Default Value	500

Index 2180: CAN Restart Time

With this index, the restart time for the CAN communication in case of a Bus-Off error is defined. The value is set in milliseconds.

0 (zero) disables this function.

Index	2180
Name	CAN Restart Time
Description	-
Data Type	Unsigned 16
Access	r/w
PDO Mapping	No
Value Range	0...50000
Default Value	1000 (restart after one second)

DS401: digital inputs

Index 6000: Read Digital Input 8 Bit

This index represents the values of the digital inputs.

Index	6000
Name	Digital Input 8 Bit
Description	-
Data Type	Array

Index	6000.00
Name	Number of indexes supported
Description	
Data Type	Unsigned 8
Access	r/o
PDO Mapping	No
Value Range	-
Default Value	-

Bit 0 = 0: Channel disabled

Bit 0 = 1: Channel enabled

Bit 1 = 0: Channel inactive (drives no PWM)

Bit 1 = 1: Channel active (drives PWM)

Index	6000.01...6000.xx
Name	Digital Input 8 Bit
Description	
Data Type	Unsigned 8
Access	r/o
PDO Mapping	Yes
Value Range	-
Default Value	-

Index 6100: Read Digital Input 16 Bit

Same specifications as index 6000, only with 16-bit-access.

Index 6120: Read Digital Input 32 Bit

Same specifications as index 6000, only with 32-bit-access.

Index 6005: Global Interrupt Enable

This index enables a global interrupt without changing the setups of the interrupt masks. In event mode the values are transmitted depending on indexes 6006, 6007, 6008 und the transmission type.

TRUE (1) = interrupt enable
FALSE (0) = interrupt disable

Index	6005
Name	Global Interrupt Enable
Description	-
Data Type	Boolean
Access	r/w
PDO Mapping	No
Value Range	-
Default Value	TRUE

Index 6006: Interrupt Mask Any Change

This index gives whether an interrupt is created by any change. If enabled, both rising and falling edges are considered valid. Interrupts trigger PDO transmissions in event mode.

1 = Interrupt enable
0 = Interrupt disable

Index	6006
Name	Interrupt Mask any change
Description	-
Data Type	Array

Index	6006.00
Name	Number of indexes supported
Description	
Data Type	Unsigned 8
Access	r/o
PDO Mapping	No
Value Range	-
Default Value	-

Index	6006.01...6006.xx
Name	Interrupt Mask any change
Description	
Data Type	Unsigned 8
Access	r/w
PDO Mapping	No
Value Range	-
Default Value	0xFF (interrupt enabled)

Index 6007: Interrupt Mask Low to High

Same specifications as index 6006, but only rising edges are valid. Default is 0 (zero) (disabled).

Index 6008: Interrupt Mask High to Low

Same specifications as index 6006, but only falling edges are valid. Default is 0 (zero) (disabled).

DS401: digital outputs

Index 5200: Output Reset on Error Option

This index determines whether the outputs restore their original states after acknowledging and dealing with a critical error.

0 (zero) maintains the original states of index 6200.xx. In case of an error, the outputs are set according to indexes 6206 and 6207. After the error cleared, the states of index 6200.xx are restored.

1 and greater overwrites the outputs permanently. The original states are not restored, since index 6200.xx is overwritten with the safe-states of error handling.

Index	5200
Name	Output Reset on Error Option
Description	-
Data Type	Unsigned 8
Access	r/w
PDO Mapping	No
Value Range	-
Default Value	1

Index 6200: Write to Digital Output

With this index the digital outputs are set.

Index	6200
Name	Write to digital output
Description	-
Data Type	Array

Index	6200.00
Name	Number of indexes supported
Description	
Data Type	Unsigned 8
Access	r/o
PDO Mapping	No
Value Range	-
Default Value	-

Bit 0 = 0: Channel disabled

Bit 0 = 1: Channel enabled

Index	6200.01...6200.xx
Name	Write to digital output
Description	
Data Type	Unsigned 8
Access	r/w
PDO Mapping	Yes
Value Range	-
Default Value	0

Index 6300: Write Digital Output 16 Bit

Same specifications as index 6200, only with 16-bit-access.

Index 6320: Write Digital Output 32 Bit

Same specifications as index 6200, only with 32-bit-access.

Index 6206: Error Mode Output 8 Bit

With this is set, whether the outputs change to predefined states (index 6207) in case of an error.

Index	6206
Name	Error Mode Output 8 Bit
Description	-
Data Type	Array

Index	6206.00
Name	Number of indexes supported
Description	
Data Type	Unsigned 8
Access	r/o
PDO Mapping	No
Value Range	-
Default Value	-

1 = output changes according to index 6207

0 = output does not change

Index	6206.01...6206.xx
Name	Error Mode Output 8 Bit Byte 0
Description	
Data Type	Unsigned 8
Access	r/w
PDO Mapping	No
Value Range	-
Default Value	0xFF

Index 6207: Error Value Output 8 Bit

With this index, the error states for the outputs are predefined.

Index	6207
Name	Error Value Output 8 Bit
Description	-
Data Type	Array

Index	6207.00
Name	Number of indexes supported
Description	
Data Type	Unsigned 8
Access	r/o
PDO Mapping	No
Value Range	-
Default Value	-

0 = output disabled

1 = output enabled

Index	6207.01...6207.xx
Name	Error Value Output 8 Bit Byte 0
Description	
Data Type	Unsigned 8
Access	r/w
PDO Mapping	No
Value Range	-
Default Value	0 (Inactive, high level)

DS401: analog inputs

Index 6401: Read Analog Input

With this index, the analog inputs are read.

Index	6401
Name	Read Analog Input
Description	-
Data Type	Array

Index	6401.00
Name	Number of indexes supported
Description	
Data Type	Unsigned 8
Access	r/o
PDO Mapping	No
Value Range	-
Default Value	-

Index	6401.01...6401.xx
Name	Read analog input
Description	
Data Type	Signed 16
Access	r/o
PDO Mapping	Yes
Value Range	-
Default Value	-

Index 6421: Analog Input Interrupt Trigger

With this index, the user selects the trigger conditions.

Index	6421
Name	Analog Input Interrupt Trigger
Description	-
Data Type	Array

Index	6421.00
Name	Number of indexes supported
Description	
Data Type	Unsigned 8
Access	r/o
PDO Mapping	No
Value Range	-
Default Value	-

- Bit 0: Input voltage greater than upper level
- Bit 1: Input voltage less than lower level
- Bit 2: Input changed more than delta
- Bit 3: Input reduced more than negative delta
- Bit 4: Input increased more than positive delta
- Bit 5...7: reserved (must be forced to 0 (zero))

Index	6421.01...6421.xx
Name	Analog Input Interrupt Trigger
Description	
Data Type	Unsigned 8
Access	r/w
PDO Mapping	Yes
Value Range	-
Default Value	7

Index 6423: Analog Input Interrupt Enable

This index enables/disables the global interrupt for analog input signals.

Disabled by default, to avoid bus overloads because of analog transmissions.

1 (true): enabled

0 (false): disabled

Index	6423
Name	Analog Input Interrupt Enable
Description	
Data Type	Boolean
Access	r/w
PDO Mapping	No
Value Range	-
Default Value	0 (false)

Index 6424: Analog Input Upper Limit

With this index, the upper limits for analog interrupts are set (for signal \geq limit).

Index	6424
Name	Analog Input Upper Limit
Description	-
Data Type	Array

Index	6424.00
Name	Number of indexes supported
Description	
Data Type	Unsigned 8
Access	r/o
PDO Mapping	No
Value Range	-
Default Value	-

Index	6424.01...6424.xx
Name	Analog Input Upper Limit
Description	
Data Type	Integer 32
Access	r/w
PDO Mapping	No
Value Range	-
Default Value	0

Index 6425: Analog Input Lower Limit

With this index, the lower limits for analog interrupts are set (for signal < limit).

Index	6425
Name	Analog Input Lower Limit
Description	-
Data Type	Array

Index	6425.00
Name	Number of indexes supported
Description	
Data Type	Unsigned 8
Access	r/o
PDO Mapping	No
Value Range	-
Default Value	-

Index	6425.01...6425.xx
Name	Analog Input Lower Limit
Description	
Data Type	Integer 32
Access	r/w
PDO Mapping	No
Value Range	-
Default Value	0

Index 6426: Analog Input Interrupt Delta

With this index, the signal changes (delta) for analog interrupts are set (any change at all, reducing or increasing).

Index	6426
Name	Analog Input Interrupt Delta
Description	-
Data Type	Array

Index	6426.00
Name	Number of indexes supported
Description	
Data Type	Unsigned 8
Access	r/o
PDO Mapping	No
Value Range	-
Default Value	-

Index	6426.01...6426.xx
Name	Analog Input Interrupt Delta
Description	
Data Type	Integer 32
Access	r/w
PDO Mapping	No
Value Range	-
Default Value	0

Index 6427: Analog Input Negative Delta

With this index, the negative signal changes (delta) for analog interrupts are set (reducing only).

Index	6427
Name	Analog Input Negative Delta
Description	-
Data Type	Array

Index	6427.00
Name	Number of indexes supported
Description	
Data Type	Unsigned 8
Access	r/o
PDO Mapping	No
Value Range	-
Default Value	-

Index	6427.01...6427.xx
Name	Analog Input Negative Delta
Description	
Data Type	Integer 32
Access	r/w
PDO Mapping	No
Value Range	-
Default Value	0

Index 6428: Analog Input Positive Delta

With this index, the positive signal changes (delta) for analog interrupts are set (increasing only).

Index	6428
Name	Analog Input Positive Delta
Description	-
Data Type	Array

Index	6428.00
Name	Number of indexes supported
Description	
Data Type	Unsigned 8
Access	r/o
PDO Mapping	No
Value Range	-
Default Value	-

Index	6428.01...6428.xx
Name	Analog Input Positive Delta
Description	
Data Type	Integer 32
Access	r/w
PDO Mapping	No
Value Range	-
Default Value	0

DS401: analog outputs

Index 5400: Analog Output Reset on Error

This index determines whether the outputs restore their original states after acknowledging and dealing with a critical error.

0 (zero) maintains the original states of index 6411.xx. In case of an error, the outputs are set according to indexes 6443 and 6444. After the error is dealt with, the states of index 6411.xx are restored.

1 and greater overwrites the outputs permanently. The original states are not restored, since index 6411.xx is overwritten with the safe-states of error handling.

Index	5400
Name	Output Reset on Error Option
Description	-
Data Type	Unsigned 8
Access	r/w
PDO Mapping	No
Value Range	-
Default Value	1

Index 6411: Write Analog Output

With this index, the analog outputs are set.

Index	6411
Name	Write to analog output
Description	-
Data Type	Array

Index	6411.00
Name	Number of indexes supported
Description	
Data Type	Unsigned 8
Access	r/o
PDO Mapping	No
Value Range	-
Default Value	-

Set PWM value here.

Index	6411.01...6411.xx
Name	Write analog output
Description	
Data Type	Integer 16
Access	r/w
PDO Mapping	Yes
Value Range	0x0000...0xFFFF
Default Value	0

Index 6443: Analog Output Error Mode

With this is set, whether the outputs change to predefined states (index 6444) in case of an error.

Index	6443
Name	Analog Output Error Mode
Description	-
Data Type	Array

Index	6443.00
Name	Number of indexes supported
Description	
Data Type	Unsigned 8
Access	r/o
PDO Mapping	No
Value Range	-
Default Value	-

1 = output changes according to index 6444

0 = output does not change

Index	6443.01...6443.xx
Name	Analog Output Error Mode
Description	
Data Type	Unsigned 8
Access	r/w
PDO Mapping	No
Value Range	-
Default Value	1

Index 6444: Analog Output Error Value

With this index, the error states for the outputs are predefined.

Index	6444
Name	Analog Output Error Value
Description	-
Data Type	Array

Index	6444.00
Name	Number of indexes supported
Description	
Data Type	Unsigned 8
Access	r/o
PDO Mapping	No
Value Range	-
Default Value	-

Index	6444.01...6444.xx
Name	Analog Output Error Value
Description	
Data Type	Integer 32
Access	r/w
PDO Mapping	No
Value Range	-
Default Value	0

Product related specific objects sorted by function

Current change

Index 5104: Output Driver Maximum Current

This index limits the maximum of current for the bridge driver.

Value is given in milliampere (mA)

Index	5104
Name	Output Driver Max. Current
Description	Maximum Current Limit in mA
Data Type	Array

Index	5104.00
Name	Number of indexes supported
Description	
Data Type	Unsigned 8
Access	r/o
PDO Mapping	No
Value Range	-
Default Value	2

Value of the maximum current limit in mA

Index	5104.01...5401.nn
Name	Output Driver Max. Current in mA
Description	
Data Type	Unsigned 16
Access	r/w
PDO Mapping	No
Value Range	0...2000
Default Value	1000

Index 5109: Output Current Maximum Change Prescaler

This index selects a Prescaler for index 5108.

Index	5109
Name	Output Current Change Prescaler
Description	Maximum Change of Current
Data Type	Array

Index	5109.00
Name	Number of indexes supported
Description	
Data Type	Unsigned 8
Access	r/o
PDO Mapping	No
Value Range	-
Default Value	2

Index	5109.01...5409.nn
Name	Output Current Change Prescaler
Description	
Data Type	Unsigned 16
Access	r/w
PDO Mapping	No
Value Range	1...100
Default Value	10

PWM

Index 5107: Output PWM Prescaler

This index selects the Prescaler for the PWM.

With following calculation PWM frequencies with 500 Hz...12 kHz are possible:

PWM frequency = 24 kHz (base frequency)/Prescaler

Index	5107
Name	Output PWM Prescaler
Description	Prescaler for the PWM frequency
Data Type	Unsigned 16
Access	r/w
PDO Mapping	No
Value Range	2...48
Default Value	24

Index 5108: Output PWM Maximum Change

This index limits the maximum change of current per millisecond (ms).

Index	5108
Name	Output PWM Max. Change
Description	Maximum PWM Change per ms
Data Type	Array

Index	5108.00
Name	Number of indexes supported
Description	
Data Type	Unsigned 8
Access	r/o
PDO Mapping	No
Value Range	-
Default Value	2

Value of limit for maximum current change per ms.

Index	5108.01...5108.nn
Name	Output PWM Max. Change per ms
Description	
Data Type	Unsigned 16
Access	r/w
PDO Mapping	No
Value Range	0...1000
Default Value	1

Temperature

Index 51F0: Overheat Temperature Limit

This index selects the internal operating temperature **in degree Celsius** (°C).

Exceeding this value results in shutting down the outputs (error state) and sending an emergency message.

Index	51F0
Name	Overheat Temperature Limit
Description	
Data Type	Unsigned 16
Access	r/w
PDO Mapping	No
Value Range	50...85
Default Value	65

Emergency messages

All possible emergency messages of this device have the same structure as follows:

Byte								
0	1	2	3	4	5	6	7	
EMY-Code			1001	0	CIO-Code			

EMY-Code: Error code according to DS301
 1001: Value of index 1001
 CIO-Code: Error code as unsigned 32-bit-value

CIO-Code (hex)	Change		Description
	NMT	I/O	
0000 0002	X	X	Overheat Error
1000 0000	X	X	Heartbeat Consumer Error
2000 0000			Node-Guarding Warning
3000 0000	X	X	Lifeguarding Error
4000 0000			CAN is in Error-Warning-State
8000 0000	X	X	Device was Bus-Off

The Node-Guarding warning has to be activated with index 2103.
 If more than one error occurs, the messages are combined by using logic OR.
 Some errors have to change the NMT state and/or cause a change of the output states. This behavior depends on the settings of index 1029.

The ID for emergency messages is fixed to 0x80 + Node-ID.

List of emergency messages:

A defined Heartbeat-Producer was not able to send the Heartbeat telegram.

Heartbeat Consumer Error							
30	81	01	00	00	00	00	10

The master is not able to do a RTR on the node.

Node-Guarding Warning							
30	81	01	00	00	00	00	20

The Lifeguarding time is up.

Life-Guarding Error							
30	81	11	00	00	00	00	30

The internal CAN module is in Error-Warning-State.

CAN is in Error-Warning-State							
00	81	01	00	00	00	00	40

Successful return from Bus-Off.

Return from Bus-Off							
40	81	01	00	00	00	00	80

System is overheated.

System Overheat Error							
00	10	01	00	20	00	00	00

I/O Mapping (quick reference)

2 Full-Bridge-Driver outputs EDS file: hipecs_CIO-yyy.eds ¹⁾	
Mapping in object dictionary	
Index	mapped data
6000.01	Status bridge driver 1
6000.02	Status bridge driver 2
6200.01	Control bridge driver 1
6200.02	Control bridge driver 2
6401.01	Current driver 1
6401.02	Current driver 2
6401.03	Internal temperature
6411.01	PWM Duty-Cycle driver 1
6411.02	PWM Duty-Cycle driver 2

Default PDO Mapping	
PDO	mapped data
RPDO1	6200.01 Control driver 1 6200.02 Control driver 2
RPDO2	6411.01 PWM driver 1 6411.02 PWM driver 2
TPDO1	6000.01 Status driver 1 6000.02 Status driver 2
TPDO2	6401.01 Current driver 1 6401.02 Current driver 2 6401.03 Internal temperature

¹⁾ yyy: Number of the product

History

Version	Release date	Changes/Remarks
V1.500_R000	05.04.2017	Release data sheet in new design
V1.500_R001	08.01.2020	Update: weight of module (technical data)

TOC

General.....	1
Features.....	1
CANopen Features.....	1
Ordering information.....	1
Technical data.....	2
Connectors assignment.....	3
Connector X1 (power).....	3
Connector X2 (CAN).....	3
Connector X3 (output 2).....	3
Connector X4 (output 1).....	3
Wiring diagram.....	4
Single supply.....	4
Dual supply.....	4
Configuration Dip-Switch.....	5
CAN Signal-LED.....	5
Dimensions.....	6
CANopen Object Dictionary.....	7
DS301: global objects.....	7
DS301: PDO Parameter objects.....	8
Specific objects.....	9
DS401: digital inputs.....	10
DS401: digital outputs.....	10
DS401: analog inputs.....	11
DS401: analog outputs.....	11
Product related specific objects sorted by function.....	11
Current change.....	11
PWM.....	11
Temperature.....	11
Object dictionary (description).....	12
DS301: Global objects.....	12
Index 0005.....	12
Index 0006.....	12
Index 0007.....	12
Index 1000: Device Type.....	13
Index 1001: Error Register.....	13
Index 1002: Status Register.....	13
Index 1005: COB-ID SYNC.....	14
Index 1008: Device Name.....	14
Index 1009: Hardware Version.....	14
Index 100A: Software Version.....	14
Index 100C: Guard Time.....	15
Index 100D: Life Time Factor.....	15
Index 100E: COB-ID Guard.....	15
Index 1014: COB-ID Emergency.....	15
Index 1015: Inhibit Time Emergency.....	16
Index 1016: Consumer Heartbeat Time.....	16
Index 1017: Producer Heartbeat Time.....	16
Index 1018: Identity Object.....	17
Index 1029: Error Behavior.....	18
DS301: PDO Parameter Objects.....	19

Communication Parameter Objects	19
PDO mapping objects.....	21
Specific Objects	23
Index 2000: Device Manufacturer.....	23
Index 2009: Serial Number 64 Bit.....	23
Index 2101: System Configuration	24
Index 2102: Remapping Enabled Info.....	24
Index 2103: Enabled Guarding Warning.....	24
Index 2105: Internal Error Code	24
Index 2110: Test Object	25
Index 2180: CAN Restart Time.....	25
DS401: digital inputs.....	26
Index 6000: Read Digital Input 8 Bit.....	26
Index 6100: Read Digital Input 16 Bit.....	26
Index 6120: Read Digital Input 32 Bit.....	26
Index 6005: Global Interrupt Enable	27
Index 6006: Interrupt Mask Any Change.....	27
Index 6007: Interrupt Mask Low to High.....	27
Index 6008: Interrupt Mask High to Low	27
DS401: digital outputs.....	28
Index 5200: Output Reset on Error Option.....	28
Index 6200: Write to Digital Output.....	28
Index 6300: Write Digital Output 16 Bit.....	28
Index 6320: Write Digital Output 32 Bit.....	28
Index 6206: Error Mode Output 8 Bit.....	29
Index 6207: Error Value Output 8 Bit.....	29
DS401: analog inputs	30
Index 6401: Read Analog Input	30
Index 6421: Analog Input Interrupt Trigger.....	30
Index 6423: Analog Input Interrupt Enable.....	31
Index 6424: Analog Input Upper Limit.....	31
Index 6425: Analog Input Lower Limit.....	32
Index 6426: Analog Input Interrupt Delta.....	32
Index 6427: Analog Input Negative Delta.....	33
Index 6428: Analog Input Positive Delta.....	33
DS401: analog outputs.....	34
Index 5400: Analog Output Reset on Error	34
Index 6411: Write Analog Output	34
Index 6443: Analog Output Error Mode.....	35
Index 6444: Analog Output Error Value	35
Product related specific objects sorted by function.....	36
Current change.....	36
Index 5104: Output Driver Maximum Current.....	36
Index 5109: Output Current Maximum Change Prescaler.....	37
PWM	38
Index 5107: Output PWM Prescaler	38
Index 5108: Output PWM Maximum Change	38
Temperature.....	39
Index 51F0: Overheat Temperature Limit.....	39
Emergency messages	40

List of emergency messages:	40
I/O Mapping (quick reference).....	41
History.....	42
TOC.....	43